

1. INTRODUCTION

Nortek's 80 Series is a remote video switching system, designed for the CCTV industry. Available models have either one or four independently switched output (monitor) channels. Each channel used requires a corresponding controller (keypad unit); the RC80 range provides this function.

Note that a smaller controller can be used in order to limit selection to the lower-order block of cameras; for example: - using an RC88 to control an RS816 channel would limit the operator to selection of the first eight cameras only.

	Cameras	Monitors	Matching RC
RS816	16	4	RC816
RS816CAT5	16	4 TPV	RC816CAT5
RS816/1	16	1 TPV	RC816CAT5
RS88	8 LT	4	RC88
RS88CAT5	8 LT	4 TPV	RC88CAT5
RS88/1	8 LT	1 TPV	RC88CAT5

LT – Loop Through TPV – Twisted Pair Video

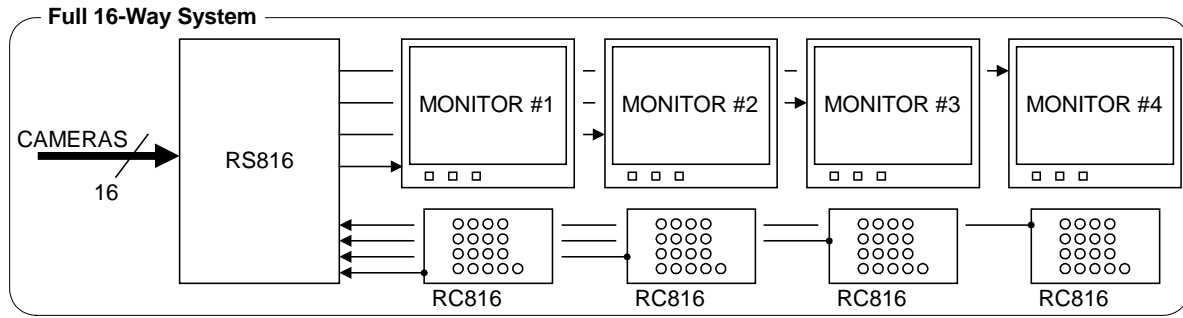

[Note that from this point onwards, any reference to the RC816 will be also apply to the RC812, RC88 & RC84]

The RC816A has an alarm facility, which provides four alarm inputs. The assignment of alarm inputs to cameras is configurable; alarm influence is local to that controller.

2. INSTALLATION

Opening the Case [WARNING: ensure power is disconnected beforehand]

RS It is only necessary to open the case for access to the 75Ω terminators or RC related screw terminals.
Procedure: - do not remove any screws! – feed a screwdriver through the hole provided in the side of the unit (**by no more than 5mm**) use it as a lever to move the lid lip away from the PCB, then lift the lid away from the unit.

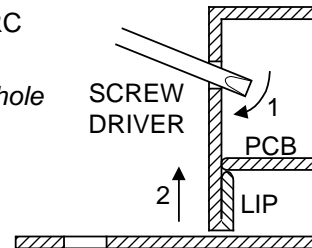

RC It is only necessary to open the case for access to the RS and alarm related screw terminals.
Procedure: - invert the RC, remove four screws, position your fingers at the front panel edge nearest the buttons and lift it away from the base.

Power Connections

The provided power adapter powers the system; this plugs into the RS unit. The RC units get their power from the RS via the CAT-5 cable.

Supplementary Earth

A supplementary earth (screw) connection is provided at the rear of the RC unit.

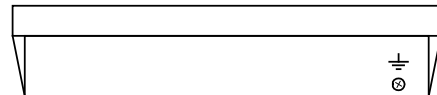

Camera Connections

We recommend populating the RS from camera-1 upwards.

The RS88 has 8 BNC pairs to facilitate loop-through; the input terminator must be removed when the loop-through facility is used.

Terminator Removal: - all inputs are 75Ω terminated; a terminator can be disconnected by removing the lid and unplugging the corresponding jumper, located directly below that camera input.

Channel Connections

The RS has up to four totally independent output channels; each channel connects to its own monitor and RC. Note that there can be only *one* RC per channel.

Connection should be made via **CAT-5 UTP** (unshielded twisted pair) cable; the cable should be no more than **150m** in length. We recommend fitting **RJ-45** connectors to the cable ends but connection may also be made via the internal screw terminals.

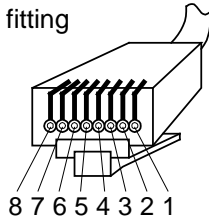

8	BRN	
7	BRN-W	
6	GRN	B
5	BLU-W	D
4	BLU	C
3	GRN-W	A
2	ORG	-
1	ORG-W	+

RC/RS Link

We've adopted the same wiring scheme as that used for standard CAT-5 Ethernet computer network cables; these are available off-the-shelf [1].

When making your own cable please refer to the **RC/RS Link** diagram - all four wire-pairs should be connected.

[1] Use straight-through cables, crossover cables are not suitable

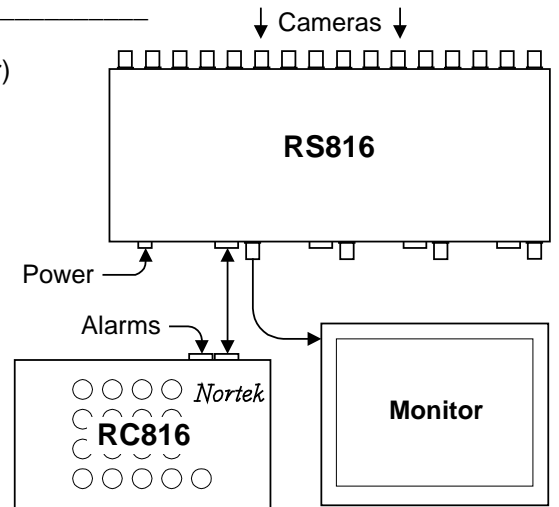

When connection is made via the internal screw terminals, we recommend using the colour scheme shown in the **RC/RS Link** diagram.

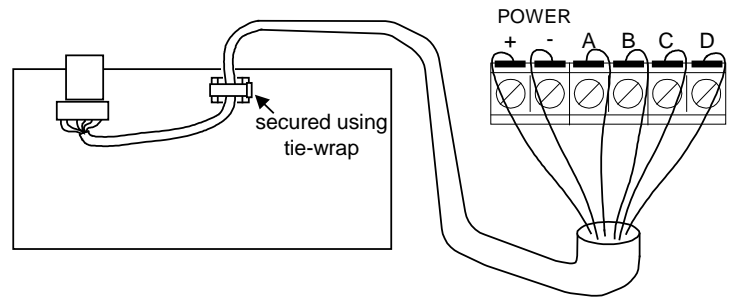

Twisted-Pair-Video Models [supplemental to the previous section]

applicable to: { RS816CAT5 :: RS816/1 :: RS88CAT5 :: RS88/1 } { RC816CAT5 }

These models have two video outputs per channel; one provides coax video via the BNC and the other provides twisted pair video via the RJ-45 connector. Both outputs have the same video content.

Twisted pair video passes through the CAT-5 control cable to the RC unit; the RC extracts the video and outputs it via coax to the monitor.

The CAT-5 cable's **brown wire pair** is used to carry the video signal, see **pins 7 & 8** on the **RC/RS LINK** diagram.

An RJ-45 connector *must* be used at the RC end of the cable, it's optional at the RS end. If an RJ-45 connector is *not* used at the RS end, then the BRN-W and BRN wires should be connected to the RS channel's V+ and V- terminals, respectively.

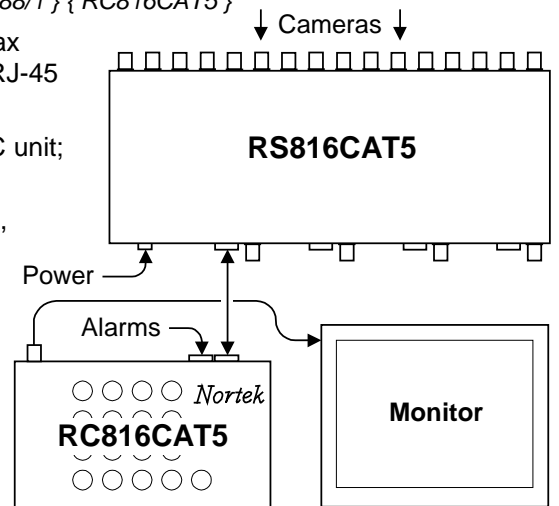

The RC has a **signal boost** option which is configured via a jumper inside the unit.

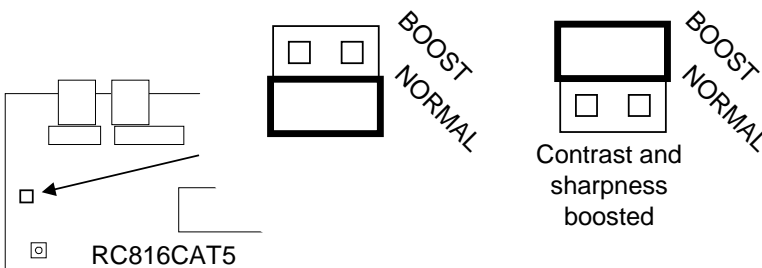

The boost should only be used when the picture looks dull and lacks detail.

Alarms [RC816A & RC816CAT5 only]

Overview

Four normally open alarm inputs are provided together with a relay contact.

Alarms act on the closing edge and are retriggerable. An alarm will switch the RC816A into alert mode, in which it will stay for a configurable minimum period. During the alert state the most recently alarmed camera is displayed.

The relay is energised for the duration of an alert.

Wiring

Connections may be made via the internal terminal block or, if preferred, via its associated **RJ-45** connector.

Connect alarm contacts to the terminals labelled **AL1, AL2, AL3, AL4** and wire their returns to **RET**; leave any unused alarm inputs unconnected. The alarm sources should be floating, voltage-free contacts.

The relay connections are *common, normally closed and normally open*; these names describe the relay state when not alerted.

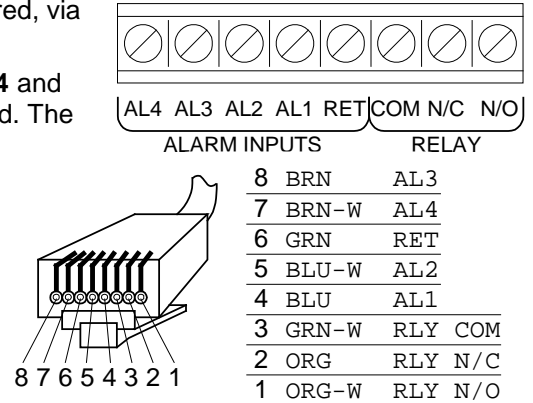
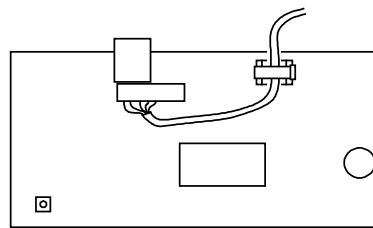

Alarms

Important Note: - All cable connections should be made using the same method, as illustrated below...

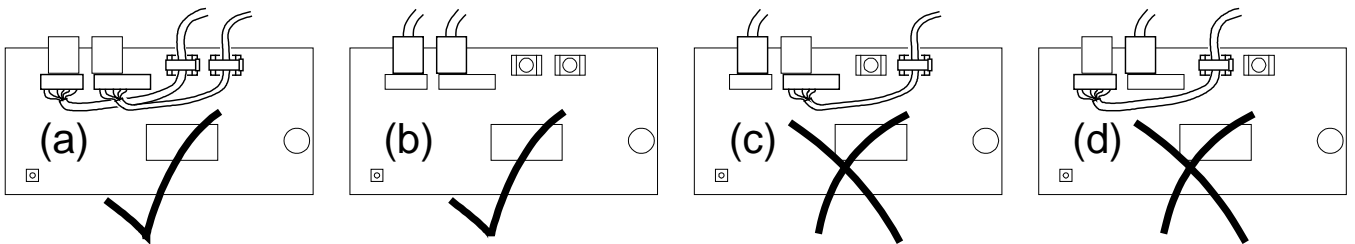

...this is because for situations (c) & (d) there is a danger of the RJ-45 plug being plugged into the vacant RJ-45 socket by mistake which would result in the two cables being shorted together. Situation (b) is also open to misconnection if the RJ-45 plugs are plugged into the wrong sockets, but in this case there is no danger of any damage occurring.

Legacy System Compatibility [RS616 / RC616 etc]

The *80 Series* is largely compatible with Nortek's now obsolete *60 Series*. Old and new units can be mixed in an installation.

Control Cable

Legacy cable installations can be re-used through use of terminal blocks within the *80 Series* units.

When installing new cabling: CAT-5 may be used for distances of less than **25m**, but longer distances require the use of **screened multicore cable**. Use the multicore cable's **screen** for the **0V** connections.

Multicore cable specification { 5 cores :: each core 7/0.2mm :: tinned copper braided screen :: 150m max. }

Terminal Block Text

The control cable power terminals are labelled differently, **+15V / 0V** on the **60 Series** correspond to **+ / -** on the **80 Series**.

3. SPECIFICATION

RS | **Video I/O** { 1V_{p-p} :: 75Ω } **RS-RC link cable** { CAT-5 UTP :: 150m max. }
Power Supply { 230Vac 50Hz :: 12Vdc @ 500mA :: unregulated :: class II }

RC | **Auto Sequencing** { 1 to 120 sec } **Current Consumption** { 60mA @ 12Vdc }
Alarm Contacts { N/O :: floating contact } **Relay Contacts** { N/O & N/C :: 12V @ 100mA }

4. RC PROGRAMMING

The RC is configured by use of a hidden switch, located under one of its rubber feet; this is the **SET** switch.

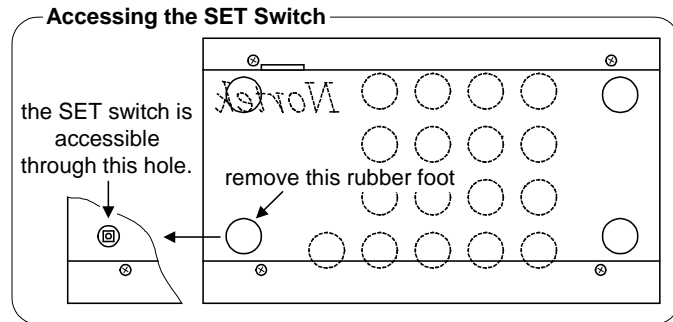

If, while in programming mode, there's no key activity for 25-secs, the unit will discard any changes and revert back to normal operation.



Configuring Cameras

The RC can be programmed to block access to certain cameras; this is done by defining which cameras are accessible; these are the only cameras the operator will be allowed to view.





Set-up Procedure

- Tap **SET**; the lamp above the  key will flash, and the lamps above the camera keys show which cameras are currently accessible.
- Tap the camera keys to toggle them to the desired state. Note that the RC demands at least two cameras be defined as accessible.
- Tap  to store the new settings and return to normal operation or alternatively tap **SET** again to cancel the set-up procedure and discard any changes.

Configuring Alarms [RC816A & RC816CAT5 only]

The alarmed version of the RC has four alarm inputs which are, by default, initially associated with cameras 1 to 4. When an alarm contact closes, the RC switches to the associated camera for a period of time and then returns to its original state.

Set-up Procedure

- Press and **hold SET** until you hear an acknowledgement, then release it; the  lamp will flash, and the camera key lamps show which cameras have an alarm association.
- To reassign the alarms - tap four camera keys in succession; for example: - tapping **3 7 12 2** will assign alarm inputs 1, 2, 3, & 4 to cameras 3, 7, 12 & 2 respectively. All but your last four entries will be ignored, so if you make a mistake just start again.
- The alert period can be set to any value in the range of 1- to 120-secs; this is done by holding down  while tapping keys **3** and **4**; each tap of **3** adds 10-secs and each tap of **4** adds 1-sec to the total; for example: - hold down  and tap **3** once and **4** twice to specify an alert period of 12-secs.
- Finally, tap  to store the new settings and return to normal operation or alternatively tap **SET** again to cancel the set-up procedure and discard any changes.

5. RC OPERATION



Note that the unit will always power-up in *auto-sequence* mode.

Camera Selection

Simply tap a camera key to view the corresponding camera, if the camera is not accessible then the unit will give a warning beep and ignore the request.

Automatic Camera Sequencing

Tap  to *start* and *stop* auto-sequencing; tapping a camera key also stops auto-sequencing.

The dwell period can be set to any value in the range of 1- to 120-secs; this is done by holding down  while tapping keys **3** and **4**; each tap of **3** adds 10-secs and each tap of **4** adds 1-sec to the total; for example: - hold down  and tap **3** once and **4** twice to get a dwell period of 12-secs.

Alarms [RC816A & RC816CAT5 only]

When alarmed, the lamp of the alarmed camera will flash and when the alert period ends the unit will return to its original state. An alert can be cancelled manually by tapping any of the keys.