

PIP92 - Installation & Operation

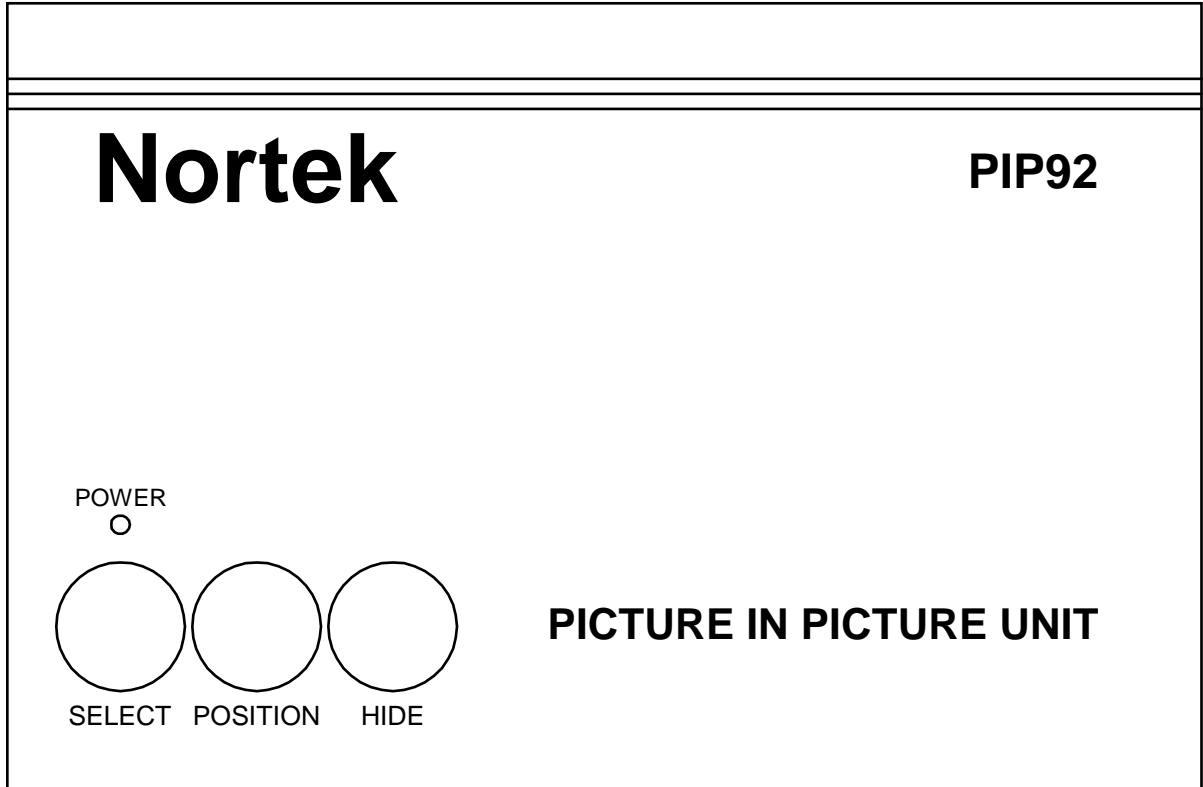

Contents

1. INSTALLATION.....	3
1.1. OVERVIEW	3
1.2. CONFIGURATION.....	3
1.3. ALARMS	4
2. SPECIFICATIONS.....	4

SAFETY

Please read these instructions carefully and keep them for future reference. Any queries should be furthered to Nortek technical support on +44 (0) 1260 276 409.

WARNINGS! • This unit should only be installed by qualified personnel.

Power Supply

The provided power supply unit (Class II double insulated / isolated) should be used to power the unit.

Requirements

- The unit should be used within the boundaries of its specifications.
- The unit's environment must be dry and dust-free.
- Shield from direct sunlight and keep away from sources of intense heat.
- Avoid humid conditions.
- Ensure free ventilation.

Hazards

Remove power from the unit and refer to authorised service personnel in the event of any of the following:

- liquid is spilled onto the unit.
- the unit is damaged in any way.

Electromagnetic Compatibility (EMC)

This product is intended for use in residential, commercial or light industrial EMC environments.

Warning! This is a Class A product. In a domestic environment this product may cause radio interference in which case the user may be required to take adequate measures.

Manufacturer's Declaration of Conformance

The manufacturer declares that this product is compliant with EC Directives 89/336/EEC and LVD 73/23 EEC, relating to the following standards:

- EN50081-1 (EN55014, EN55022) for emissions.
- EN50082-1 (IEC801-2, IEC801-3, IEC801-4) for immunity.
- EN60950 for electrical equipment safety.

Subject to the following conditions:

- The installer must follow the recommendations contained within this document
-

1. INSTALLATION

1.1. Overview

The PIP92 is a 2-way video switcher incorporating a picture-in-picture function. The installer can configure the size, position and border colour of the inset picture. The operator can alter the position and visibility of the inset picture and can select the video source.

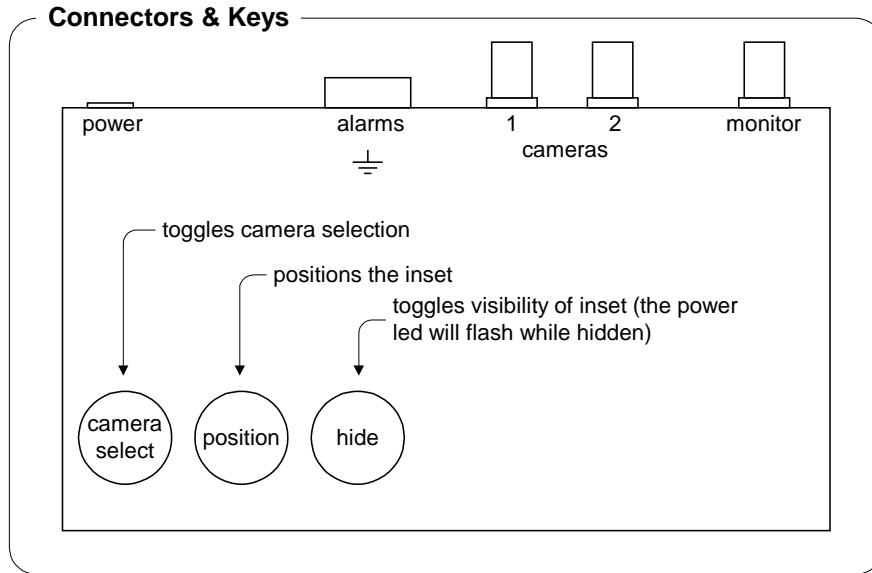

A supplementary earth (screw) connection is provided, it's located beneath the alarm connector.

1.2. Configuration

The PIP92 leaves the factory configured as follows...

- inset position:** *top left*
- inset size:** *small*
- border colour:** *dark blue*
- terminators:** *both inputs terminated*

You can alter these settings by opening the PIP92 case (just remove the four screws) - then adjust the jumpers as required.

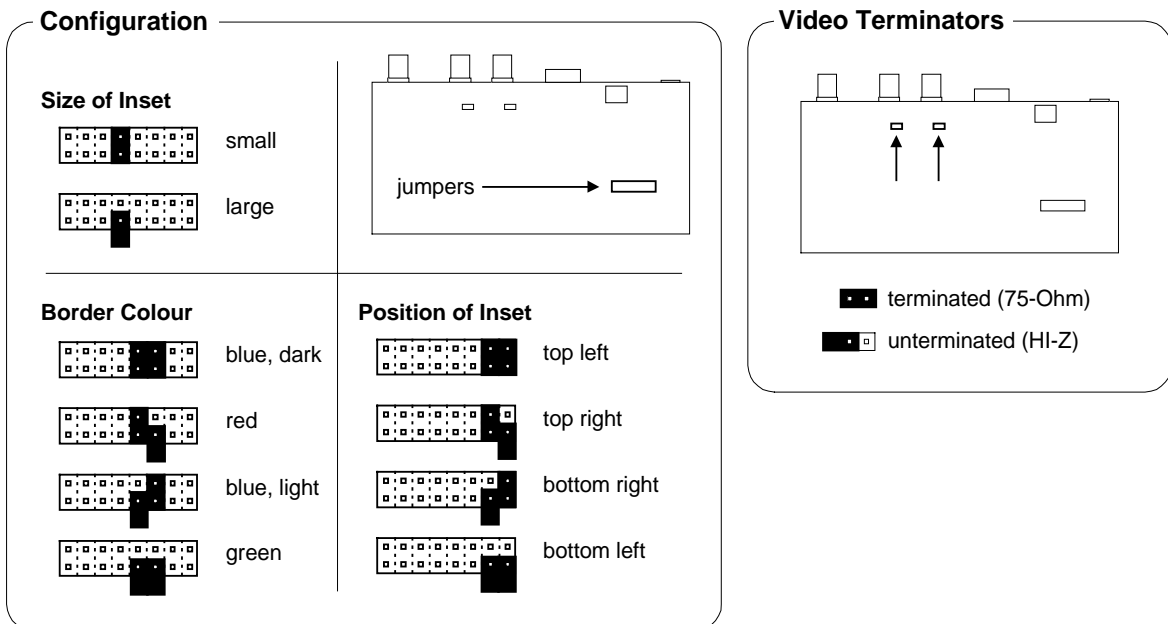

1.3. Alarms

Camera selection can be controlled remotely via the alarm inputs. The leading edge of an alarm action will select the associated camera as the main picture. If you require the unit to revert back to the other camera when the alarm ends then use a change-over relay to feed the alarm inputs.

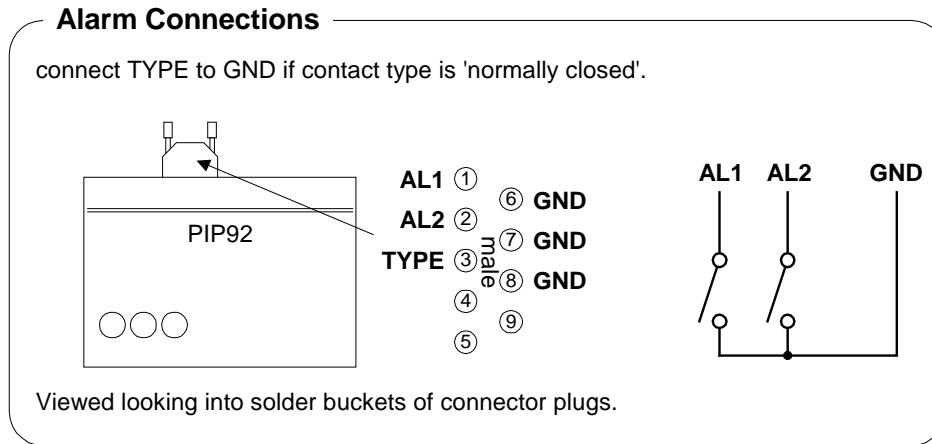

2. SPECIFICATIONS

Video

- Camera Inputs: 2; internal jumpers facilitate removal of 75Ω terminators
- Video Outputs: 1
- Format: composite video 75Ω 1V_{pk-pk}, PAL 625-line 50Hz
- Connectors: BNC

Alarms

- Alarm Inputs: 2; contact types can be either N/O or N/C
- Function: selects the main image source

Inset

- Sizes: 2; both having aspect ratio of 4:3
- Small: approx. 1/3 x 1/3
- Large: approx. 1/2 x 1/2
- Positions: 4 (each corner)
- Method: scaled digital image; 7-bit; 50 fields/sec

Power

- Supply Requirements: 10V, 300mA
- Connector: D.C. Socket 2.1mm

Power Adapter

- Input: 230Vac +/- 10%, 50Hz.
- Output: 9Vdc @ 500mA, unregulated; class II.

Dimensions (mm)

- L x W x H: 157 x 110 x 40